

STK# 10267 and 10269



300 mm and 400 mm Tile Cutter **OWNER'S MANUAL**



Made in China
QEP Australia Pty. Limited
www.qep.com
Y807

WARNING! ALWAYS USE SAFETY GLASSES.
Everyday eyeglasses only have impact-resistant
lenses – they are not safety glasses.

GENERAL INSTRUCTIONS

1. Place the tile, glazed side up, against the most forward position of the cutter against the ruled stop. Gently place the cutting wheel on the rear edge of the tile (**FIG. A**). Using firm pressure, push the handle down and forward across the tile (**FIG. B**). The wheel will score the tile as it is pushed forward. Make sure to score the tile across the entire length of the tile. It is important to make this scoring "cut" in one continuous motion, scoring only once per tile.



FIG. A

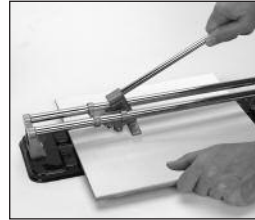

FIG. B

2. After scoring, and without moving the tile, position the handle so that the breaker bar is directly above the tile's front edge at the stop (**FIG. C**). Apply gentle pressure on the handle with both hands until the tile snaps along the score line (**FIG. D**).



FIG. C



FIG. D

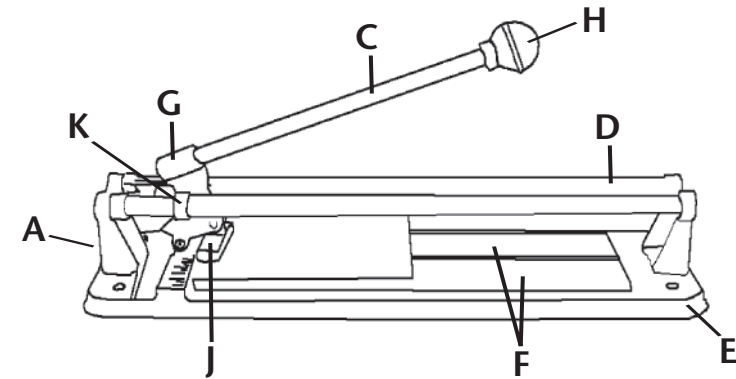

DIAGRAM LETTER

DIAGRAM LETTER	DESCRIPTION
A	Rail Post
C	Handle with Knob
D	Rail Bars (2)
E	Metal Base
F	Replacement Pads (2)
G	Yoke
H	Knob Only
J	Breaker Bar
K	Slide Assembly

NOTES:

1. Oil should not be used on the Tile Cutter. Use of oil will cause eventual gumming and sticking of the movable parts as the oil combines with dirt and ceramic tile dust.
2. Wear is normal in the chrome plated rails and can be evenly distributed by occasional rotation of each of the two rails. For cutters with hex bolts holding the rails, loosen each hex bolt and slightly rotate the rails. Retighten the hex bolts when finished.
3. The only part routinely needing replacement is the carbide-scoring wheel. (Use Q.E.P. # 10010HD 12 mm Tungsten Carbide Scoring Wheel)