

10630 & 10900 PARTS LIST

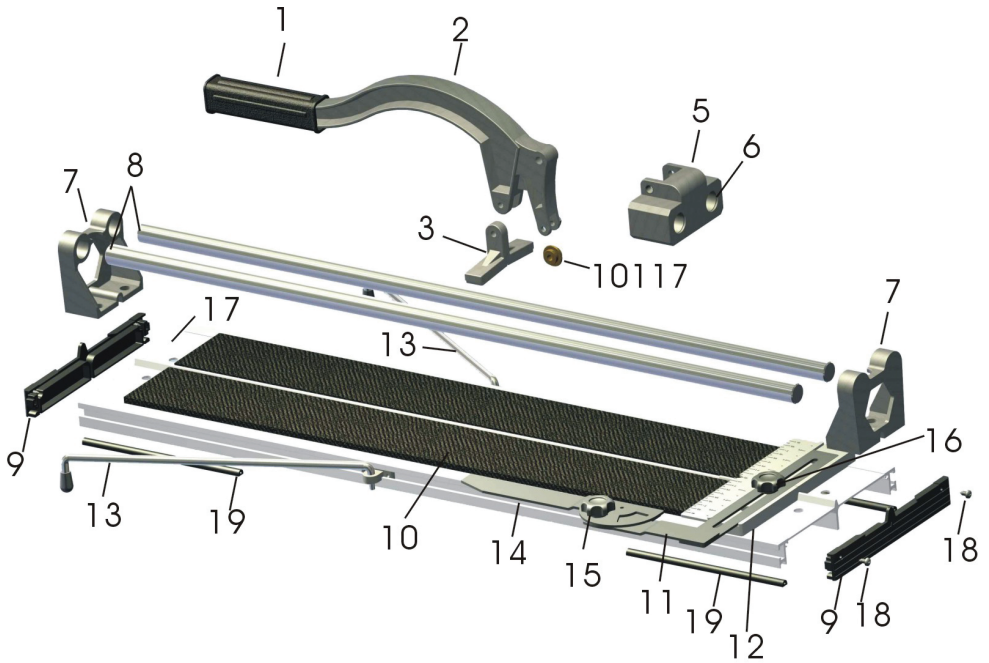

No.	Description	Qty
10900-1	Grip	1
10900-2	Handle	1
10900-3	Breaker Bar	1
21125	7/8" Cutting Wheel	1
10900-5	Slide Assembly	1
10900-6	Bearings	2
10900-7	Support	2
10900-8	Rail Bar	2
10900-9	Non-slip Pad	2
10900-10	Sponge Cushion	2

No.	Description	Qty
10900-11	Slide Rule	1
10900-12	Guide	1
10900-13	Extension Arms (10900)	2
10630-13	Extension Arms (10630)	2
10900-14	Angle Guide	1
10900-15	Angle Guide Knob	1
10900-16	Slide Rule Guide Knob	1
10900-17	Base (10900)	1
10630-17	Base (10630)	1
10900-18	Screws	4
10900-19	Rubber	4

GENERAL MAINTENANCE

- Oil should not be used on the 10630 and 10900 QEP Tile Cutters. Use of oil will cause eventual gumming and sticking of the movable parts as the oil combines with dirt and ceramic tile dust – use a soft dry cloth to clean the rails after each use.
- Wear is normal in the chrome plated rails and can be evenly distributed by occasional rotation of each of the two rails.
- The only part routinely needing replacement is the carbide scoring wheel.