

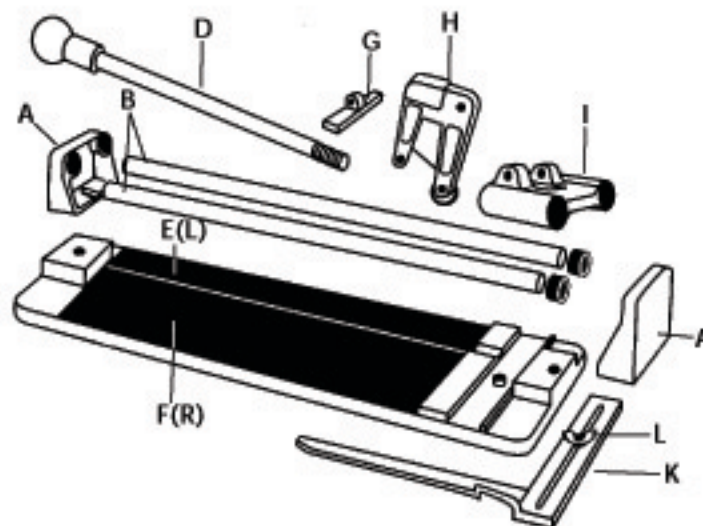

No. 21044 17" Pro Ball Bearing Tile Cutter

ORDER NO.	DESCRIPTION
21044*	Box
21044-A	End Bracket
21044-B	Rail Bars (2)
21044-D	Handle with Knob
21044-EF	Replacement Pads (2)
21044-G	Breaker Bar
21044-H	Yoke
21044-I	Slide Assembly
21044-K	Guide
21044-L	Wing Nut
10117	7/8" Titanium Coated Tungsten Carbide Cutting Wheel
10119	7/8" Tungsten Carbide Cutting Wheel





ORDER FORM

ORDER NO.	DESCRIPTION	QUANTITY	PRICE	TOTAL

Subtotal	
Shipping & Handling	* 7.95
Total Amount	

To Order:

Fax to 561-241-2830

or

Mail to Q.E.P. Co., Inc.
1001 Broken Sound, NW Suite A
Boca Raton, FL 33487

* Shipping & Handling may vary depending on weight and dimensions of product.

Name: _____

Address: _____

City: _____ State: _____ Zip: _____

Phone #: _____ Daytime Phone #: _____

Payment: CHECK VISA MASTER CARD

Credit Card #:

Expires: / /

Billing Credit Card Zip Code: -

Signature: _____ Date: _____